

cowpat hill

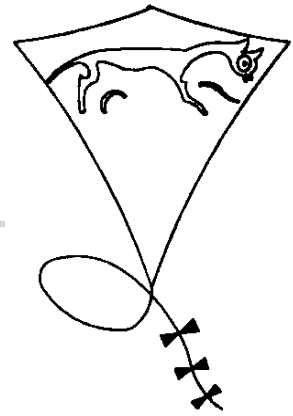

WHITE HORSE KITE FLYERS
SUMMER ISSUE 2004
JULY - OCTOBER

Middle Wallop Kite and Buggy Event – August 2004

Due to the much bigger turnout at the last Middle Wallop event combined with the current demands that are being placed upon us as organisers, we have had no choice but to cancel the August event.

Over the last few years the landowners and other relevant parties have been placing ever more financial demands on us. As the event has grown safety has become ever more a concern. To ensure not just the safety of competitors but most importantly the safety of third parties there is a need for greater investment into the event.

The landowners once again require more money than we can currently raise from the existing set-up, so we need to take a step back and re-think how we can successfully continue to organise the Middle Wallop events.

After considering all the restrictions and demands being imposed upon us and the immediate need for much larger investment we now will turn all our efforts into bringing you an even better event for May 2005. This only affects the Middle Wallop event and we are at present trying to organise another event for 2004. Details will be posted as and when they become available.

Information will be posted reference 2005 festival dates as soon as they become available

White horse kite flyers
PO Box 585
SWINDON
SN3 4YR

Diary Dates 2004

W =Workshop, D = Display, T = Teddy bears

July

10/11 Brighton
16/17/18 CHILTERN SHOW JULY {W,D,T}
17 Stroud show (W)
17/18 Kennett Valley CANCELLED
17/18 Hereford
24/25 Tewkesbury
25 Petworth

August

7/8 Middle Wallop CANCELLED
15 Lackham college (W,D,T)
14/15 Coventry
28/30 Portsmouth
29/30 Uffington show (W,D)

September

4/5 Bristol
5 Brinkworth show (W,D)
5 Bowood House {W}
11/19 Dieppe
12 Rockingham Castle {W,T}

October

10 Barbury One Sky One World

November

14 Barbury
21 A.G.M The Greenbridge Pub
see web site for map or ask before hand
More details in next issue

Please note all events are liable to alteration or cancellation for up to date information please check our web site www.white-horse-kite-flyers.org.uk

ROBINSON'S RAMBLE

Well the weather tried it's hardest to ruin this years festival, but it didn't succeed! The rain was so persistent on the Saturday I thought the monsoon season had begun, and then to get to the site on Sunday and be surrounded in low cloud was the last straw! However despite all of that we had 2.000 + people come through the gate on Sunday, we even had in excess of 400 on Saturday! I feel they were all rewarded by our guest's displays in the Hangar. Our Guest Mikio Toki, did us proud with his lessons on paper folded kites in the Hangar, plus all of the other things going on in there including a display by our guest's from the rocket club, there launches were spectacular also! Then we have to thank Janneke Groen from Holland for the static display of here wonderful kites. And of course the fantastic display of historic kites displayed by our guests from Germany, they were over the moon with the kites that were at the Science Museum for them to see. And last but not least, the wonderful Gibson Girl Display put on by members of our own club.

What a surprise to get Peter Linn turn up, I had heard a rumour that he might try to get there but I never thought it would happen, he was passing through the UK with his friends Peter & Anne Whitehead also from New Zealand and Bill Furber from Australia, from an event in Cervia, Italy. Peter was extremely excited by the Science Museum site, especially a Benz car that was being exhibited there, in fact Peter is an expert on these vehicles and he told me that the one there may be the oldest car in the World! He wants to come back some time to investigative work on it.

The Buggy brigade had a great time and want to come back, I just wish we had more grass space for them, John Eaton from the BBC informs me that the runways are great, but only for the very experienced Buggier's.

This years raffle broke a record again with Marla and her helpers extracted in excess of £700! Thanks must go to all of you who donated prizes and of course for digging very deep into your pockets to buy tickets, the raffle as become vital to the event, without it I doubt whether the festival would continue. ***THANKYOU! TO YOU ALL, AND A SPECIAL THANKYOU TO MARLA.***

We had a meeting arranged with Joanna from the Science Museum, on Tuesday 29/06/04, but at 8 o'clock this evening; (Monday 28/06/04)) I received an email from Joanna to say she couldn't get to the meeting, and wouldn't be able to arrange another meeting until at least August, because her diary was so full! After some frantic phone calls to Arthur and Neil, we thought it best to make an executive decision and set a date for next years Festival, even though we haven't got the confirmation of a venue yet, it was felt that if we didn't do this, some other festival may take our date. So the date for next year will be 7/8th May 2005. If we fail to get the Science Museum site I will open up negotiations with Swindon Council to get Lydiard Park again.

Dave Robinson

Dear Kite friends.

The Todd Ward Fund.

On behalf of my family, I wish to let you know that on Tuesday the 15th of June I went to Kings College Hospital London SE5, with my son Danny, his wife Katrina and Simon Hennessey. This was to present the Todd Ward staff with a cheque for **£6466.79p**. This magnificent amount was the sum total of all the amazingly generous donations to the fund, set up as a thank you to Todd Ward for looking after Pat and doing everything that could be done.

The fund will be used to buy a portable heart monitor that can be used at the patients' bedside, a very useful piece of equipment for the ward.
The unit will carry a dedication to Pat.

I wish to thank every one most sincerely for your help and support to help me get through this difficult time since Pat died.

Bless you all and may your god go with you.

Fair winds, blue sky's.

Thank you

Ron Dell.



15/06/04

King's College Hospital NHS Trust
Institute of Liver Studies,
King's College Hospital
Denmark Hill, London, SE5 9RS
020 7737 4000

Zebina Ratansi
Clinical Nurse Leader
Liver Intensive Therapy Unit
☎020 7346 3714
E-mail: zebina.ratansi@kingsch.nhs.uk

Dear Mr Dell,

Re: Donation to the Todd Ward Fund

Thank you so very much for your generous donation of £6466.79 in memory of Pat. This money is very gratefully received and has been put into a special trustee account.

As discussed this morning, the money will go toward purchasing a transoesophageal echocardiography and transthoracic echocardiograph machines, which cost approximately £5000.00.

On behalf of Dr. Wendon and the LITU team we would like to convey our sincere gratitude to all those who participated in this fund raising campaign.

It was very nice to have met you all this morning.

Thank you again for your support and generosity.

With kind regards,

Zebina Ratansi
Clinical Nurse Leader, LITU

Crumbs from the Hi chair

After reading the last two magazines I can see that my general article just says the same as Sky Chat (Retired), Robinson's Ramblings and Web Wonderings but in different words. I am therefore going to stop this as a regular feature and go back to my old ways with random articles when something takes my fancy.

If anything special happens then I will re-use this title but until then, who knows. A low wind Weymouth, a wet Swindon, Cleethorpes and Wallop not done by me then a quiet Bedford has been the recent sequence. I hope some one else has done something about Westmill Wind Farm, Wilton Windmill and Butser Hill. At least the Transit of Venus was clear. For a report on Fano see my main article.

There's lots of other small events coming up so please watch the forum for details as this is the only way we can get information out to you in time.

Web site still looking good and forum being used by a few. Mainly the same ones as use the Friday chat room.

Arthur

FANO 2004-06-23

Wednesday afternoon 5 of us met up at Harwich and loaded all our gear into Jerry's Previa. Everything went in including the case of beer, bottles of wine, gin, vodka, whiskey, rum..... A bit of a game getting the car with top box into a place where it did not foul the upper deck but all was well and we sailed on time at 18.00. Located our very pleasant inboard cabin and went for a meal. This was where the rot started: smoked salmon, prawns, cray fish, smoked halibut, more prawns and that was just the starter. This was followed by roast beef veg, salad; desserts, cheese and biscuits washed down with a couple of bottles of wine then to the bar for coffee and,,,,,, that was the way the weekend continued.

A passable nights sleep in some very low bunks and very flat crossing had us up by 09.00 for breakfast. Docking in Esbjerg at mid day local time and a new game to get the car off, got us to the Fano ferry just in time to see one leave. This did give us time to pick up some post cards that got home 5 hours before we did. Only 30 minutes wait and we were at sea again for the short crossing and into Nordby tourist office to pick up the apartment keys. We were lucky to have the help of Brian, Mary and Mark who had done it all many times before and they led us to the apartment. We stopped only long enough to drop off some bags and then drove ¼ mile to the beach.

The site that met our eyes was one we shall never forget. There is no way words can do it justice but the five of us with combined kiting experience of over 100 years just stood there gob-smacked. 14 kilometres of hard sand up to ½ kilometre wide with up to 8000 kites in the air!!! The buggies had a dedicated 5-kilometre stretch and with winds force 5 to 6 straight off the North Sea were those boys motoring?

We drove the length of the beach taking photographs all the way. It is safe to drive on the sand and there is even a bus route running the full length. We came off at the southern end and went back via a super market to pick up provisions for evening meals and breakfast.

Friday morning we were on the beach early, (well, before mid-day) and with the high wind choice of a kite was difficult but Jerry decided the answer was the large Bol. We used a metre square sand drag buried a metre deep and thought this would hold it so we inflated it. I wish some one had had a video camera running, the sand drag didn't even try and it was off down the beach: Jerry dived on it; I dived on it; two of us and half a ton of sand would have left any buggy behind had it not been for 3 heavy duty lines we found holding down even larger kites. We will have the bruises for some time to remember this entertainment.

We had taken very few kites suitable for these wind speeds and gradually collected a pile requiring Franchesca (hope I've spelt it right this time), Jon and Jerry to spend evenings repairing them and Carolyn untangling bridles. I just kept the glasses topped up. However we did manage to get the teddy rig up under a Cody and bung a few bears. Apparently the film crew heard about this and turned up just as we had packed up so we promised to do it all again the next day and true to their word they turned up and spent an hour filming our silly games this time from a large para-sled. I can't wait to see the results when they are published in September.

On Friday evening we attended what proved to be a chance to mingle and purchase brilliant German engineered kite bits and various souvenirs such as pins and patches. Local beer and hot dogs were available if you were thirsty or hungry. Saturday evening at the same location was the auction, another indescribable event. The auctioneer doesn't stop. He moves up and down the raised gang way and if you understand the lingo he is apparently very funny. All proceeds go to supporting a third world school project.

The weather was mainly kind with only a few rain showers and some bright sky but the wind went through everything we had taken and three of us had to go to a local shop to get wind proof coats. These were at sale prices and you could get an £80 jacket for £30. The best money I spent all weekend.

When we weren't trying to fly it was walk or drive up and down the beach to marvel at the latest additions or to chat with old acquaintances.

The trip home was just the reverse of the trip out except that with a few hours to spare we did the tourist bit round the island and got to see the incredible exhibition of the early German line climber for aerial photography (If the editor wasn't pushing for this article before deadline I would sort out the inventors name)

I could have gone on about all the arches, spinners, line garbage etc. but could not hope to convey the atmosphere and spectacle. Pictures are up on my web site. Suffice it to say I WILL BE GOING BACK TO FANO.

Anybody fancy a club trip?

Arthur and The Ted Berets

A new project.

Following the success of the play-sail and wind-sock projects I would like to try a new one this year. Given more time I hope more people will contribute and come and join us for the final assembly.

I want to make a kite arch similar to the one made for the 20th Fort Worden Conference. I am indebted to Sam Huston for his assistance with information on this and Ron Miller for emailing the plans. I am changing things slightly in that I am going for folded hems rather than edging strips.

The centre kites will be green with the name WHITE HORSE KITE FLYERS and some white horse logos but outside that members can let their imagination run wild. The club will supply the spines and a workshop event will stitch them all onto the line. Colours and designs are up to the individual as long as the base shape and dimensions are adhered to. The more we get the longer the arch so get **sewing**.

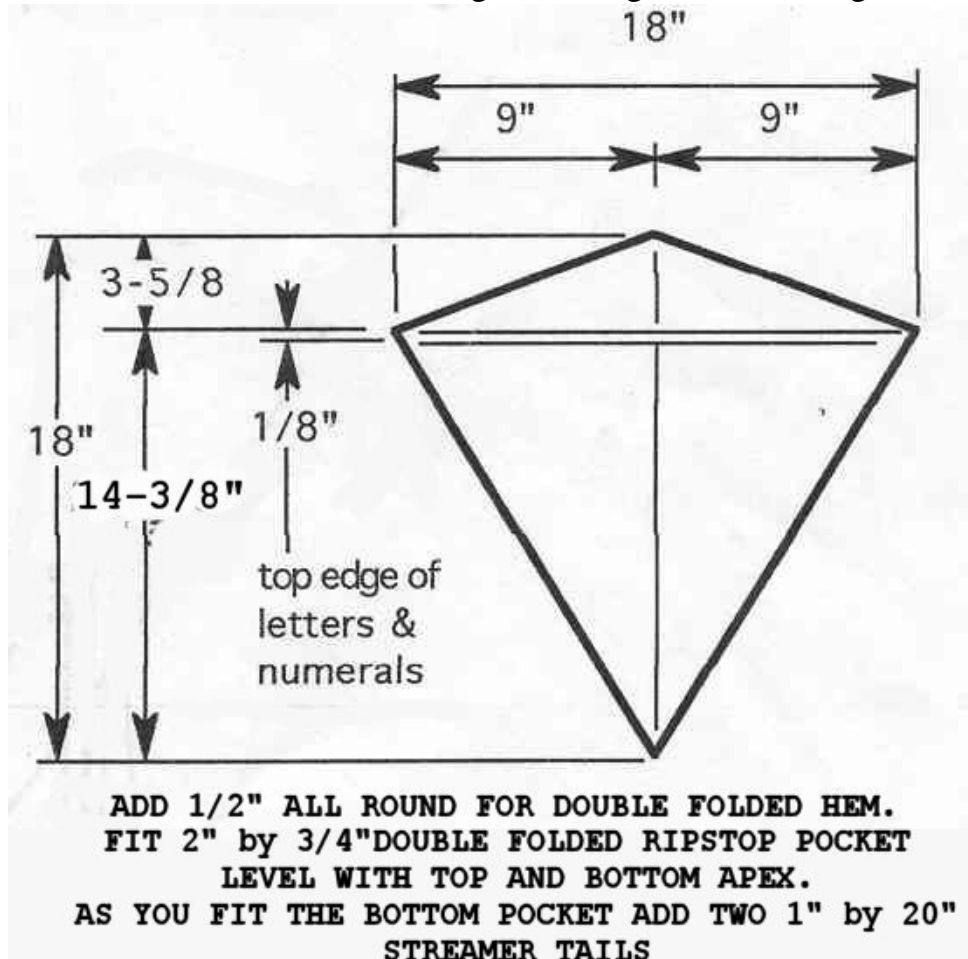

Any problems give me a call or look at the pictures at

<http://www.tedberets.co.uk/Arch.html>

Arthur.

THE CREATIVE INGENUITY OF WHITE HORSE KITEFLIERS SHONE THROUGH AT THE RECENT MARTIN LESTER WORKSHOP. WITH SEVERAL NEW VERSIONS OF THE FAMOUS "LEGS" KITE

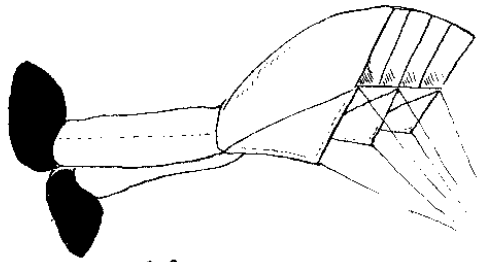

CHARLIE CHAPLIN

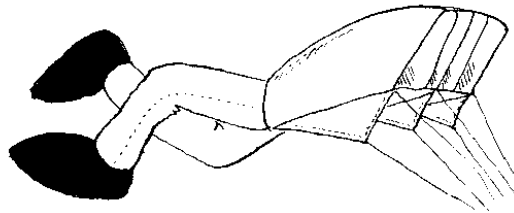

I DONT KNOW WHETHER
IM COMING OR GOING

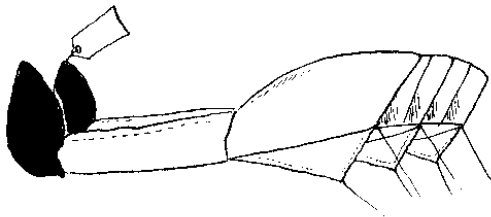

THE MORGUE

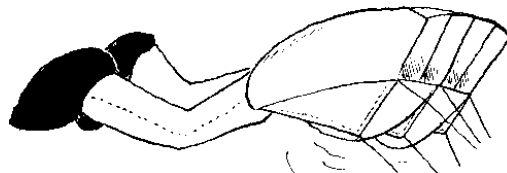

POST-VASECTOMY BLUES

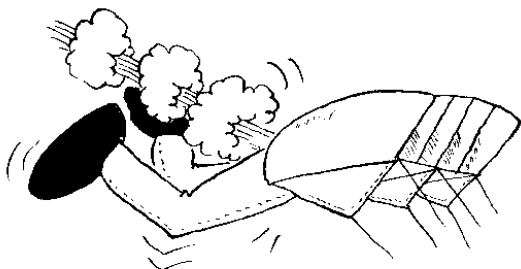

NO MORE CURRIED EGGS
FOR ME

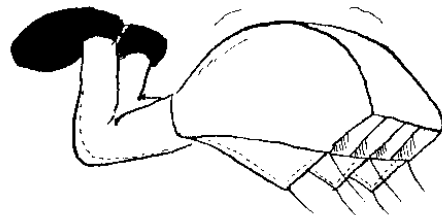

DOES MY BUM LOOK
BIG IN THIS?

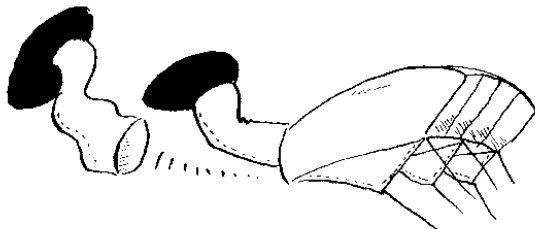

LONG JOHN SILVER

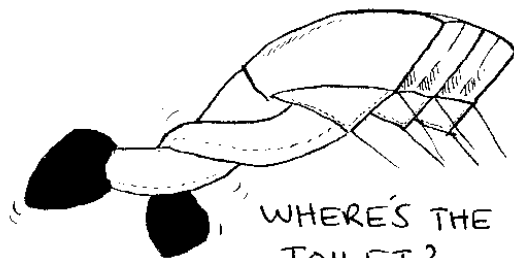

WHERE'S THE
TOILET?

Not

I'LL GET THE DAMN THING IN THE AIR... ①

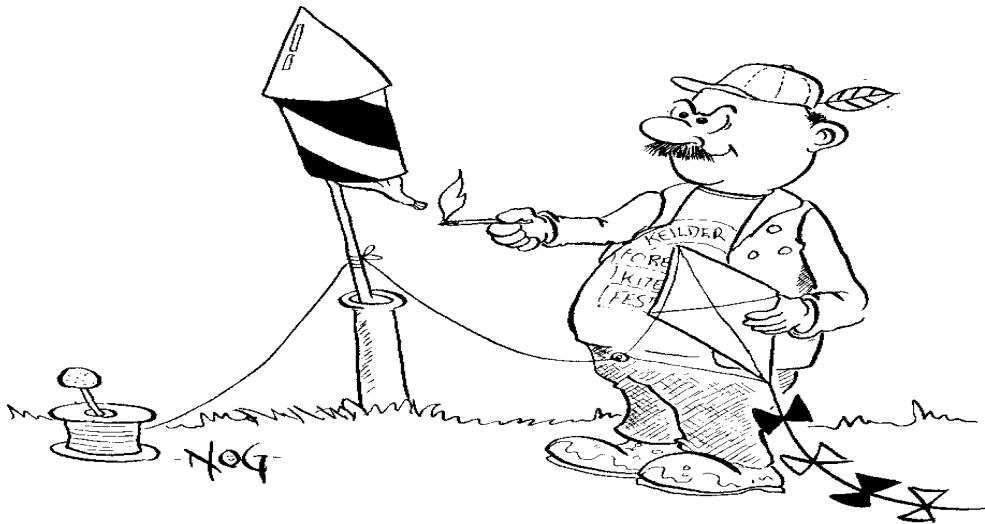

Thanks to David Cross for the cartoons.

IMPORTANT ANNOUNCEMENT

The meeting planned with Joanna from the Science Museum, on Tuesday 28/7/04 was cancelled at short notice; by her. Consequently we were unable to discuss how this years event went, (in their eyes) and of course to set a date for next year. Arthur, Neil & me then thought the best plan was to set a date, (7/8th May 2005) so that we have that date set in the Kite Calendar. I have spoken to Joanna on the phone this week, and she says that they want the event back there next year, *but* we will have to pay a fee or find a sponsor, for next year, because the Science Museum is not prepared to do the event on a shared basis in the future. I have spoken to my contact at Swindon Council and we can go back to Lydiard next year, if we fail to get Wroughton.

Regards
Dave Robinson

Kite activities getting Stopped.

As you sit there contemplating the next kite to buy/build/enjoy, spare a thought to what's going on around you! In the past week (mid June) three events over the country are showing that our sport is very much under attack.....

From the Diary page you will see a large black mark crossing out the Middle Wallop event in August - the story goes that the event is being subjected to the sins of being too successful, and there are both financial and safety pressures being the reason to it's failure.

Just this weekend I am hearing that the beach at Camber Sands, East Sussex is under threat to stop kite surfing, and possibly other forms of kiteing, an open meeting with the wardens of that area is to take place to discuss the situation, I await to hear what exactly what's happening.

But the situation is much clearer on the other side of the country - Pendine Sands in Wales is to ban ALL vehicular access onto the beach due to an incident that involved an uninsured quad bike, the child riding it with no helmet, and a parked car! This beach is world renowned for being the UK's speed records of the 1930's. But no, the council is closing the beach as of the 4th of July (nothing to celebrate there then!). Land yachts and buggies have been using it for years; organised events have run there to no-ones dismay. Talk about a knee-jerk reaction.

So why do I moan? Does these events affect me? Well, yes they do - it affects all of us! This is not a question of "Oh, those buggy boys are a menace", or "there is a need for some control that the local council should do". It's a case of complacency!

We all want to have our bit of fun and not be harassed by others! Yes I am a buggy pilot, and the loss of Pendine, where I have been and planned to visit again this year for buggying is close to my (and my son's) heart! The loss of Wallop has meant that STACK cannot run it's final round of competitions, and a number of people depended on that to get their UK rankings to compete in Euro cup in September. Camber Sands is just another beach that can be scratched off your holiday list where kites are being banned (There's bans down on some beaches in Devon and Cornwall already! if you want one closer to home, there's a common land field in Oxford with a power kite ban!).

Our hobby is under attack, and we are doing nothing to stop it, what national organisations there are seem ill equipped to respond - STACK has no effect - it's too small, BBC has the membership to act, but are staying within their aspect of the sport obviously. KSGB? Do me a favour! and our new national organisation BKFA are struggling to get started but no one will take them seriously enough until it's too late, so they do not have the mandate of enough clubs to call themselves the one "National" blanket organisation to face officialdom - one of their aims was to get Sports Council recognition for the sport as a whole, giving us a voice.

By the time you read this one beach will be closed, another under threat, Middle Wallop is the third kite festival called of this year, and STACK 'may/may not' have a new site to compete, but at a cost that'll put a number of competitors off (an extra £10

or so per competitor on top is muttered - making my entry fee for that one event to over £30).

Sorry to be so depressing, but it's coming the time to stand up and be counted if you want this sport to continue and progress. How can we resolve this, start by letting your club know you care. Think about where the BKFA, or something similar, can or should help. United we can make a difference - so long as we're not too late! But at the moment we are divided, and they are using that weakness to affect a 'fete accompli' on us all.

We thought it a joke a short while ago that I instigated a risk assessment over making our workshop kite, but this was after hearing that MKF were being asked for one, and ours has been used! The club's insurance company is now asking questions over our equipment and it's safety - extra expense!!

The incident at Lytham St Anne's two years ago and the immediate ban there is being slowly dissolved thanks to Fexifoil and others working behind the scenes, so it can be done. The one glimmer of light for Pendine is that the local club is getting backing from all over the country, though the restrictions the council has mooted are extreme (they talk of a maximum number restriction and £10m liability insurance - the first to demand this level anywhere in the country and no insurance company will touch it). At least in Essex they started to talk about the situation first, hope they can sort it out. Middle Wallop - Roy and Hailey hope to run something again next year, but in what format???

Peter Dawson.

The White Horse Raffle or Now Your Getting The Idea.

Well if we could only get the weather to shape up at this festival, we would have it made. You can say all you want, but I do remember some hot weather during past festival.

It is always fun to be with the White Horse Group no matter what the weather. Each time that I have the privilege of running the raffle or relieving you of your money (how ever you want to look at it) I am more excited that you have really "Got It". Each time I do a raffle I hold my breath to see if anyone will come and bring items, then, I wonder if we will reach the amount that we as a club need to raise, to bring the guest to these events. I really don't know how it has become my "gift" to do well at this job? I think that being a PB has something to do with it and just not taking "NO" for an answer. I can't take all the credit or even close to all the credit for how this works. It takes the wonders of all of you. Great job White Horse Club!

Thank you for letting me be part of this (as if you could get rid of me). I am already looking forward to next year.

I will be back home in August and can hardly wait to see you.

Marla

P.S. Ron did make a Spam sandwich when he got home.

P.S.S. Ask around and you will find out what PB is.

Many Thanks Indeed!

I want to thank you the White Horse Kite Flyers for the wonderful crystal fruit bowl you presented me for my 60th birthday. You really caught me off guard, which is not



easily done. I did not even see this coming. Of course I am having great difficulty handling or even trying to understand that I am 60. I just don't know if I am supposed to grow up now? I think not!

The crystal and I made it home in one piece.

When the customs agent asked if I had any fruit, I declared that I did. Then I told her it was plastic and she wanted to know if I was going to eat it?

Needles to say I am once again in my other country and missing you all very much. Thank you again for this lovely gift and for being a very important part of my life...even if I am 60. All my love,

Marla

Note from the Ed.

Well what can I say we are half way through the year already. The club has attended many festivals and events and still has many more until the end of the year. Can I remind you that I hold a Diary, and events should be phoned or e- mailed to me to go in the diary, this enables the club to find willing members to attend these events and makes sure we don't commit ourselves as a club to events we then cant find members to attend due to other commitments. The deadline for the next magazine is the **25th of September**. I look forward to receiving your articles for the next magazine I have to admit filling this one has been a struggle I know you have all attended events that you can write about so come on lets hear about them don't be shy have your say.

See you on an events field soon

Tracy

A big thank you to all who took the time to write an article for this issue as up until the two days before we put it together to go to print we only had the diary dates and cartoons and the last two only made it but an hour or so!!! Thank you Marla!! So now it's off to Mr. Harvey for sky chat Rtd, and printing

Pete

Sky Chat

During my frequent visits to the Doctor I'm, asked if I'm depressed. My answer is no. I'm frustrated not being able to do what I want to do through lack of energy. But just recently I have become more depressed by more and yet more rules and regulations and the general approach of the growing band of "Jobsworths" It seems if anybody is having fun or doing some good to their fellow mankind; there are twice as many trying to stop them. Either quoting "Health and Safety" or charging fees that will automatically kill any enthusiasm to try and carry on. We are now losing Kite Festivals at too fast a rate and it will get worse I fear. It is not just our Kite Festivals that are being lost. It seems that other events are in the same boat. Just read or hear on TV that another event has gone because the insurance has rocketed out of all proportions or the police/council says that you must have this that or the other which kills the event stone dead. It seems to me that the only people that have a smile on their faces are the insurance brokers and the ones with the biggest grins, the legal profession in all its guises. What's wrong in having fun and taking risks to get the adrenalin going, or are we going to be nannyed by the State and wrapped in cottonwool from cradle to the grave!!!! URGH.

While I'm on my high horse, please as a Committee use the old dog and bone a little more instead of e-mail. I may be old fashion, but when you put something out on e-mail it is gone in a flash and cannot be retrieved. Where as when you phone somebody you can at least discuss it. O.K. to confirm what has been said and to let other members know then. That's better now it is off my chest.

On the Kite front things have been going on quite smoothly. Festivals at Cleethorpes and Bedford were not the mad rush of past years. Much more enjoyable, probably due to the fact that the Kite were not subsidised by the two councils and we had increased the price this year. The Committee are still trying to sort out our own festival for next year and will be keeping you informed of developments. As for this year's festival we will have to forget the weather and think of the good things. The displays in the hangar were great and thanks must go out to all those that helped. Some what short notice due to the dreaded weather. It was great to see so many foreign Kite Flyers there, I feel embarrassed that we as a Club could not help them with expenses. Perhaps one day we **will** find a sponsor. Once again I must thank you all for the donations and to the money that you spent on the Raffle and to that woman Marla Miller and her helpers in prising so much money out of your pockets.

Now to those of you that may not have heard Sue and I have a grandson. Carl and Amie produced a bouncing baby of 8lbs 3ozs. Austin William on 2nd of July 2004. Another kite flyer in the making.

Neil.

A1 to B2

or

Four Days of H.E.L.L.

There I was trying to run my last AGM as chairman of the White Horse Kite Flyers last November when this rotund gentleman told me to sit down in an easy reclining fold up chair that he had produced and put my feet up. He then went on about that I could go to Heathrow Airport to do some aircraft spotting in the very near future. Four days to be exact. Strange? Why should I want to go plane spotting in the middle of November when it would be much nicer during the warmer months of summer? Then he tells me of the CATCH. I must also go early in the morning to Heathrow Terminal 3 and catch one of these big silver birds out to Chicago then change to a smaller bird to a place called Dayton, Ohio and this could all be done by early evening where a Taxi would waiting to transport me to The Hope Hotel. Was I past redemption and in need of some extraordinary treatment for some incurable complaint? The Hope Hotel in the middle of an American Air Force Base and named after Bob Hope, was I that sad a case? Really worrying, the restaurant is called "The Paki" is this politically correct? Phew! It's alright Paki is the name used by Bob Hope in his boxing days. After having a meal, which is an experience in it's self. One whole wall is devoted to the great god of the modern age Television. Not one but five huge screens, including one where you can play non-stop quizzes up to mastermind level. I decided discretion was the better part of valour and went off to bed.

Next day after breakfast a taxi trip, paid by you lot after all those dollars were thrust into my hand "that Sunday" into the centre of this Air Base. All around the grounds there were aircraft and missiles. Now was I that bad a Chairman that you wanted me put into orbit or something? No as I got closer I could see that this was the home of "The United States Air Force Museum". As usual in America everything is on a massive scale, starting with the Car Parks, good job the taxi takes you to the entrance. Once inside and greeted by a sculpture of Icarus, time to find my bearings. There is no charge for the Museum, so to get a guide book and sally forth. First resist the temptation of the bookshop and gift centre (I won't spell it the American way) and down to the hangars. Just a quick browse into a couple of the hangars before lunch as I had noticed that there was a guided tour starting at 1.15pm. Again, using my brain I thought this is going to be a long old walk and I don't think my legs are going to stand up to it. Plan "B" get a buggy, so off to the desk and get some wheels. Well I don't know which creaked more, me and my bones or the buggy, still off we went at a steady rate of knots. Now the tour guide was a bit of a wit so we were in for some fun. To start with he said "If anybody asks where is the Corsair is I will not be responsible for my actions" Reason being to you non aircraft buffs is that it is a **Naval** plane. So when I said I was ex Fleet Air Arm, that brought forth the comment "not just a naval bod but a limey as well"

Well off on the tour starting with the early years. Now before going any further the aim of the Museum is to have a representative of every aircraft that has served in the USA Air Force, plus a few others of historical interest. To date they have about 430 aircraft on their books of which about 340 are on display at any one time and this does not include the missiles and satellites. As you can imaging this is the start of what can be a very long journey.

To be continued. (Can you stand the suspense?)

Neil.

Club Merchandise

Club merchandise is available to buy including tee shirts, polo shirts, sweat shirts, polo sweat shirts, caps, winter hats and patches all with club logo on. To order please contact us at address on front page or on web site www.white-horse-kite-flyers.org.uk . where all merchandise can be seen. Latest prices are on request.

Kite Flying Safety Tips

The NEVERS of Kite Flying

- Fly a kite in wet or stormy weather, try to keep your kite line dry.
 - Fly a kite near power lines, transmission towers or aeriels.
 - Fly a kite with wire or anything metallic in the line.
 - Fly a strong pulling kite without wearing GLOVES.
 - Leave odd bits of flying line etc on the flying site.
 - Fly a kite at over 200 feet*.
- *Kite festivals may have C.A.A. clearance to fly higher.....ASK!

The Things to AVOID

- Motorways, roads, car parks railway lines or buildings.
 - Airfields and low flying air traffic patterns.
 - Members of the public....stunt flyers please take care!
 - Those kite eating trees.
 - Animals, they can be frightened by kites.
- Remember...your kites can get really quite lonely up high in the sky, just occasionally, look up and give them a little SMILE.*

... AND PLEASE, MIND THOSE POWER LINES!

Where the WHKF go to fly their kites

WHITE HORSE KITE FLYERS fly at Barbury Castle Country Park, Wroughton, Swindon, Wilts on the SECOND Sunday of each month
Will YOU be there?

Local WHKF contacts are:
Neil Harvey on: (01285) 740295
Arthur Dibble on: (01635) 865976
Dave Robinson on: (01793) 824208

COWPAT HILL
Journal of the White Horse Kite Flyers
Editor Tracy Willis
WHKF School Bungalow Alton Close Penhill Swindon Wilts SN2 5HF
Tel 01793 706516
e-mail cowpat.ed@whkf.org.uk
Club Subscription: £10.00 (One year UK)
(including postage and kite flying insurance)

Whilst every care is taken when compiling this journal the WHKF cannot accept responsibility for any errors or omissions which may occur.